



Specifications

Model	Line Voltage (VAC)	Armature Voltage Range (VDC)	Continuous Armature Current (Amps)	Horsepower Range
MHS443-10	115 230	0 - 90 0 - 180	10	1/4 - 1 1/2 - 2

AC Line Voltage.....115/230 VAC ± 10%, 50/60 Hz, single phase
Form Factor.....1.37 at base speed
Field Voltage with 115 VAC line voltage.....50 or 100 VDC
with 230 VAC line voltage.....100 or 200 VDC
Maximum Field Current.....1 Amp
Acceleration Time Range.....0.5 - 12 seconds
Deceleration Time Range.....coast to stop - 12 seconds
Analog Input Voltage (S1 to S2).....0 - 5; 0 - 10 VDC
Current Range (S1 to S2).....4 - 20 mA
Input Impedance (S1 to S2).....>100K ohms
Load Regulation with Armature Feedback.....1% base speed or better
with Tachogenerator Feedback.....0.1% base speed
Speed Range with Armature Feedback.....60:1
with Tachogenerator Feedback.....80:1
Vibration (0 - 50 Hz).....0.5G maximum
(>50 Hz).....0.1G maximum
Ambient Temperature Range.....10°C - 45°C
Weight.....7.8 lbs
Safety Certifications.....UL/cUL Listed Equipment, file # E132235
CSA Certified Component, file # LR41380

Safety Warnings

READ ALL SAFETY WARNINGS BEFORE INSTALLING THIS EQUIPMENT

- **DO NOT INSTALL, REMOVE, OR REWIRE THIS EQUIPMENT WITH POWER APPLIED.** Have a qualified electrical technician install, adjust and service this equipment. Follow the National Electrical Code and all other applicable electrical and safety codes, including the provisions of the Occupational Safety and Health Act (OSHA), when installing equipment.
- **Circuit potentials are at 115 or 230 VAC above earth ground.** Avoid direct contact with the printed circuit board or with circuit elements to prevent the risk of serious injury or fatality. Use a non-metallic screwdriver for adjusting the calibration trim pots. Use approved personal protection equipment and insulated tools if working on this drive with power applied.
- Reduce the chance of an electrical fire, shock, or explosion by using proper grounding techniques, over-current protection, thermal protection, and enclosure. Follow sound maintenance procedures.
- **Removing AC line power is the only acceptable method for emergency stopping.** Do not use dynamic braking, decelerating to minimum speed, or coasting to a stop for emergency stopping. They may not stop a drive that is malfunctioning. Removing AC line power is the only acceptable method for emergency stopping.
- Line starting and stopping (applying and removing AC line voltage) is recommended for infrequent starting and stopping of a drive only. Dynamic braking, decelerating to minimum speed, or coasting to a stop is recommended for frequent starts and stops. Frequent starting and stopping can produce high torque. This may cause damage to motors.
- **Do not disconnect any of the motor leads from the drive** unless power is removed or the drive is disabled. Opening any one lead while the drive is running may destroy the drive.
- The field output is for shunt wound motors only. Do not make any connections to terminals 4 and 5 when using a permanent magnet motor.
- Change voltage switch settings only when the drive is disconnected from AC line voltage. Make sure both switches are set to their correct position. If the switches are improperly set to a lower voltage position, the motor will not run at full voltage and may cause damage to the transformer. If the switches are improperly set to a higher voltage, the motor will overspeed, which may cause motor damage, or result in bodily injury or loss of life.
- Under no circumstances should power and logic level wires be bundled together.

Dimensions

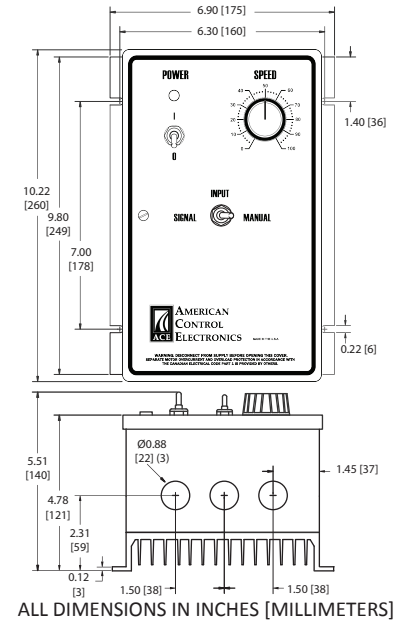

Installation

Mounting

NEMA 4X cased drives come with two 0.88 inch (22 mm) conduit knockout holes at the bottom of the case. The drives may be vertically wall mounted using the four 0.19 inch (5 mm) slotted holes on the attached heat sink. For loads less than 5 amps, the drives may be bench mounted horizontally or operated without mounting.

1. Install the mounting screws.
2. For access to the terminal strip, turn the slotted screw on the front cover counterclockwise until it is free from the case. The right side of the cover is hinged to the case. Pull the slotted screw to open the case.
3. Carefully remove the conduit knockouts by tapping them into the case and twisting them off with pliers.
4. Set the POWER switch to the OFF position before applying AC line voltage.
5. Install conduit hardware through the 0.88 inch (22 mm) knockout holes. Connect external wiring to the terminal block.
6. Grasp the slotted screw and tilt the front cover back into place. Avoid pinching any wires between the front cover and the case.
7. Turn the slotted screw clockwise until tight to secure the front cover.

Wiring

Use 18 - 24 AWG wire for logic wiring. Use 14 - 16 AWG wire for AC line and motor wiring.

Shielding Guidelines

As a general rule, ACE recommends shielding of all conductors. If it is not practical to shield power conductors, ACE recommends shielding all logic-level leads. If shielding of logic-level leads is not practical, the user should twist all logic leads with themselves to minimize induced noise. It may be necessary to earth ground the shielded cable. If noise is produced by devices other than the drive, ground the shield at the drive end. If noise is generated by the drive, ground the shield at the end away from the drive. Do not ground both ends of the shield.

Fusing

MHS403 series drives provide on board fusing for the AC line (L1, L2 (230)). Fuses are fast acting fuses rated for 15A at 250 VAC.

Connections

Line Input

Connect the AC line power leads to terminals 1 (L1) and 3 (L2 (115V)) if using 115 VAC line power or to terminals 1 (L1) and 2 (L2 (230V)) if using 230 VAC line power.

Motor

Connect the DC armature leads to terminals 6 and 7. If the motor does not spin in the desired direction, power down the drive and reverse these connections.

Field

At 115 VAC, connect the field leads to terminals 4 and 1 for a 50 VDC field or to 4 and 5 for a 100 VDC field. At 230 VAC, connect the field leads to terminals 4 and 1 for a 100 VDC field or to 4 and 5 for a 200 VDC field. **Do not make any connections to 4 and 5 if using a permanent magnet motor.**

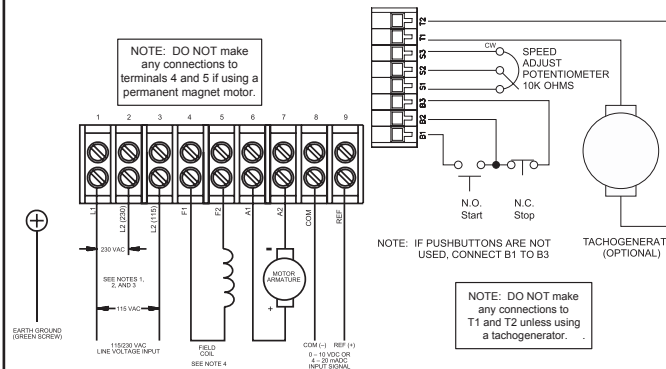

POWER

LOGIC

Speed Potentiometer (Pre-wired)

MHS443 series drives are pre-installed with a 10K ohm, 1/4 W potentiometer for speed control.

Signal/Manual Switch (Pre-wired)

Instead of using a speed adjust potentiometer, MHS series drives may be wired to follow an analog input signal. This input signal can be in the form of voltage (0-10 VDC) or current (4-20 mA). Because these drives have built in isolation, the input signal can be grounded or ungrounded (floating). Connect the signal common (-) to terminal 8 and the signal reference (+) to terminal 9.

Start/Stop Switch

To use start and stop switches, connect a normally open push button to terminals B1 and B2. Connect a normally closed push button to terminals B2 and B3. If no switches are desired, wire a jumper between B1 and B3 if no switches are desired, wire a jumper between terminals B1 and B3 (preinstalled). **Do not use the stop switch for emergency stopping.**

Tachogenerator

Using tachogenerator feedback improves speed regulation from approximately 1% of motor base speed to approximately 0.1% of motor base speed. Use tachogenerators rated from 7 VDC per 1000 RPM to 50 VDC per 1000 RPM. Connect the tachogenerator to terminals T1 and T2 of terminal block TB502. The polarity is positive (+) for T1 and negative (-) for T2 when the motor is running in the forward direction (A1 is positive in respect to A2). Place SW505 in the TACH position. The TACH trim pot must be adjusted prior to operating with tachogenerator feedback. Refer to the Calibration section for instructions on calibrating the TACH trim pot.

Startup

SELECT SWITCHES

Input Voltage Select (SW501, SW502)
Set the voltage switch SW501 and SW502 to either 115 or 230 to match the AC line voltage.

Armature Voltage Select (SW503)
Set the voltage switch SW503 to either 90V or 180V to match the maximum armature voltage.

Signal Select (SW504)
Set the signal select switch to either CURR to use a 4-20 mA analog signal or to VOLT to use a 0-10 VDC analog signal or potentiometer.

Feedback Select (SW505)
Set the feedback select switch SW505 to either ARM for armature feedback or TACH for tachogenerator feedback.

- Verify that no foreign conductive material is present on the printed circuit board.
- Ensure that all switches are properly set.

1. If using MANUAL mode, turn the speed adjust potentiometer to "0" (full CCW). If using SIGNAL mode, set the analog input voltage or current signal to minimum.
2. Set the POWER switch to the ON position.
3. If using MANUAL mode, slowly advance the speed adjust potentiometer clockwise (CW). If using SIGNAL mode, slowly increase the analog input voltage or current signal. The motor slowly accelerates as the potentiometer is turned CW or as the analog input voltage or current signal is increased. Continue until the desired speed is reached.
4. Set the POWER switch to the OFF position to coast the motor to a stop.

LEDs

Current Limit (CL): Red LED lights whenever the drive reaches current limit.
Power (PWR): Green LED lights whenever AC line voltage is applied to the drive.

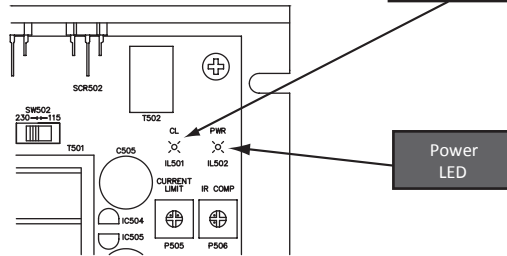

MODES

Signal Mode

Set the SIGNAL/MANUAL switch on the front cover to SIGNAL if you want to control the motor speed using either a 0 - 10 VDC voltage or a 4 - 20 mA current signal. Signal Select switch SW504 should ALWAYS be set to VOLT. If using a 4-20 mA current signal, leave the 510 ohm resistor between terminals 8 and 9. If using a 0-10 VDC voltage signal, remove the 510 ohm resistor between terminals 8 and 9.

Manual Mode

Set the SIGNAL/MANUAL switch on the front cover to MANUAL if you want to control the motor speed using the speed adjust potentiometer mounted on the drive cover. Signal Select switch SW504 should ALWAYS be set to VOLT.

Copyright 2012 by American Control Electronics® - All rights reserved. No part of this document may be reproduced or retransmitted in any form without written permission from American Control Electronics®. The information and technical data in this document are subject to change without notice. American Control Electronics® makes no warranty of any kind with respect to this material, including, but not limited to, the implied warranties of its merchantability and fitness for a given purpose. American Control Electronics® assumes no responsibility for any errors that may appear in this document and makes no commitment to update or to keep current the information in this document.

Operation

DECELERATING & STOPPING

Decelerate to Minimum Speed

The switch shown below may be used to decelerate a motor to a minimum speed. Closing the switch between S1 and S2 decelerates the motor from set speed to a minimum speed determined by the MIN SPD trim pot setting. If the MIN SPD trim pot is adjusted to zero speed, the motor decelerates to zero speed when the switch between S1 and S2 is closed. The DECEL trim pot setting determines the rate at which the drive decelerates. By opening the switch, the motor accelerates to set speed at a rate determined by the ACCEL trim pot setting.

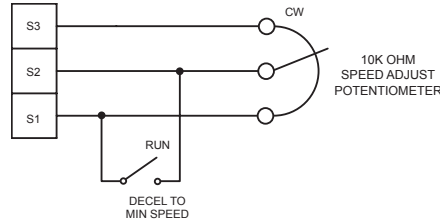

Decelerate to Zero Speed (Coast)

See Start/Stop in the CONNECTIONS section on page 1 for a description of wiring and connection locations.

Decelerate to Zero Speed (Dynamic Brake)

Dynamic braking may be used to rapidly stop a motor. For the RUN/BRAKE switch, use a two pole, two position switch rated for at least the armature voltage rating and 150% of the armature current rating. For the dynamic brake resistor, use a 40 watt minimum, high power, wirewound resistor. Sizing the dynamic brake resistor depends on load inertia, motor voltage, and braking time. Use a lower-value, higher-wattage dynamic brake resistor to stop a motor more rapidly. Recommended values are 15 ohms for a 90 VDC motor and 30 ohms for 180 VDC motor.

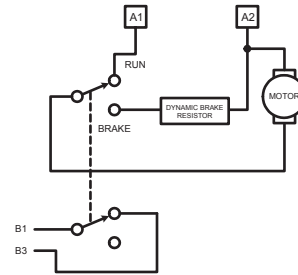

REVERSING

Reversing with a Dynamic Brake

A dynamic brake may be used when reversing the motor direction. Use a three pole, three position switch rated for at least the armature voltage rating and 150% of the armature current rating. For the dynamic brake resistor, use a 40 watt minimum, high power, wirewound resistor. Sizing the dynamic brake resistor depends on load inertia, motor voltage, and braking time. Use a lower-value, higher-wattage dynamic brake resistor to stop a motor more rapidly. Recommended values are 15 ohms for a 90 VDC motor and 30 ohms for 180 VDC motor. **The motor must come to a complete stop before changing directions.**

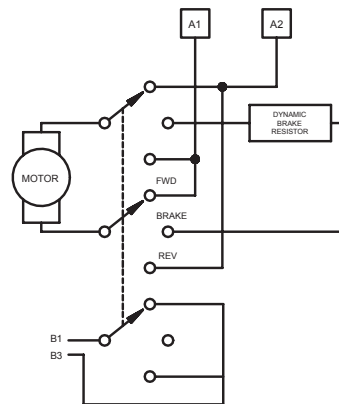

Calibration

Minimum Speed (MIN SPD): The MIN SPD setting determines the minimum motor speed when the speed adjust potentiometer or input voltage or current signal is set for minimum speed. It is factory set for zero speed. To calibrate the MIN SPD:

1. Set the speed adjust potentiometer or input voltage or current signal for minimum speed.
2. Adjust the MIN SPD trim pot until the desired minimum speed is reached or is just at the threshold of rotation.

Maximum Speed (MAX SPD): The MAX SPD setting determines the maximum motor speed when the speed adjust potentiometer or input voltage or current signal is set for maximum speed. To calibrate the MAX SPD:

1. Set the speed adjust potentiometer or input voltage or current signal for maximum speed.
2. Adjust the MAX SPD trim pot until the desired maximum speed is reached.

Check the MIN SPD and MAX SPD adjustments after recalibrating to verify that the motor runs at the desired minimum and maximum speed.

Torque (CURRENT LIMIT): The CURRENT LIMIT setting determines the maximum torque for accelerating and driving the motor. To calibrate the CURRENT LIMIT:

1. With the power disconnected from the drive, connect a DC ammeter in series with the armature.
2. Set the CURRENT LIMIT trim pot to minimum (full CCW).
3. Set the speed adjust potentiometer (full CW) or input voltage or current signal to maximum speed.
4. Carefully lock the motor armature. Be sure that the motor is firmly mounted.
5. Apply line power. The motor should be stopped.
6. Slowly adjust the CURRENT LIMIT trim pot CW until the armature current is 150% of motor rated armature current. **Continuous operation beyond this rating may damage the motor.**
7. Turn the speed adjust potentiometer CCW or decrease the input voltage or current signal.
8. Remove line power.
9. Remove the stall from the motor.
10. Remove the ammeter in series with the motor armature if it is no longer needed.

IR Compensation (IR COMP): The IR COMP setting determines the degree to which motor speed is held constant as the motor load changes. To calibrate the IR COMP:

1. Set the IR COMP trim pot full CCW.
2. Increase the speed adjust potentiometer or input voltage or current signal until the motor runs at midspeed without load. A handheld tachometer may be used to measure motor speed.
3. Load the motor armature to its full load armature current rating. The motor should slow down.
4. While keeping the load on the motor, rotate the IR COMP trim pot until the motor runs at the speed measured in step 2. If the motor oscillates (overcompensation), the IR COMP trim pot may be set too high (CW). Turn the IR COMP trim pot CCW to stabilize the motor.
5. Unload the motor.

Acceleration (ACCEL): The ACCEL setting determines the time the motor takes to ramp to a higher speed. ACCEL is factory set for the shortest acceleration time (full CCW). To calibrate the ACCEL:

1. Set the speed adjust potentiometer or input voltage or current signal for minimum speed. Measure the time it takes the motor to go from minimum speed to maximum speed.
2. Set the speed adjust potentiometer or input voltage or current signal for maximum speed. Measure the time it takes the motor to go from maximum speed to minimum speed.
3. If the time measured in step 2 is not the desired acceleration time, turn the ACCEL trim pot CW for a longer acceleration time, or CCW for a shorter acceleration time. Repeat steps 1 through 3 until the acceleration time is correct.

Deceleration (DECEL): The DECEL setting determines the time the motor takes to ramp to a lower speed. DECEL is factory set for the shortest deceleration time (full CCW). To calibrate the DECEL:

1. Set the speed adjust potentiometer or input voltage or current signal for maximum speed.
2. Set the speed adjust potentiometer or input voltage or current signal for minimum speed. Measure the time it takes the motor to go from maximum speed to minimum speed.
3. If the time measured in step 2 is not the desired deceleration time, turn the DECEL trim pot CW for a longer deceleration time, or CCW for a shorter deceleration time. Repeat steps 1 through 3 until the deceleration time is correct.

Tachogenerator Feedback (TACH VOLTS): The TACH VOLTS setting, like IR COMP setting, determines the degree to which motor speed is held constant as the motor load changes. To calibrate the TACH VOLTS trim pot:

1. Connect the tachogenerator to T1 and T2. The polarity is positive (+) for T1 and negative (-) for T2 when the motor is running in the forward direction (A1 is positive in respect to A2).
2. Set the feedback select switch SW505 to ARM for armature feedback.
3. Set the speed adjust potentiometer or input voltage or current signal to maximum speed. Measure the armature voltage across A1 and A2 using a voltmeter.
4. Set the speed adjust potentiometer or input voltage or current signal to zero speed.
5. Set SW505 to TACH for tachogenerator feedback.
6. Set the IR COMP trim pot to full CCW.
7. Set the TACH VOLTS trim pot to full CW.
8. Set the speed adjust potentiometer or input voltage or current signal to maximum speed.
9. Adjust the TACH VOLTS trim pot until the armature voltage is the same value as the voltage measured in step 3.

Check that the TACH VOLTS is properly calibrated. The motor should run at the same set speed when SW505 is set to either ARM or TACH.